



*Intelligent Solutions for Compressed Air Systems*

**With 11 mines and 20 processing plants in Europe, USA, Canada, Mexico and Asia-Pacific, Luzenac Group is the world's leading talc producer. For over 100 years, Luzenac has provided talc and talc-related minerals worldwide.**

### COMPRESSED AIR CONCERNS

The Luzenac Talc Mill in Montana, USA, experienced substantial energy waste. They noted issues with compressor reliability and inconsistent delivery of air to mill processing equipment and tools, among other challenges.

### COST-SAVING SOLUTIONS

Taking an integrated team approach, Luzenac employees, Discovery Energy Solutions, Pneu-Logic, Kaeser, VOS Electric, and Sletten Construction worked together to design and build a compressed air system using state-of-the-art Pneu-Logic PL2000 controls.

Today, Luzenac's Montana Mill has **fully automated compressed air controls** in place and realizes **annual power savings of \$92,000**.

System performance and reliability have improved, and maintenance costs have been reduced.

**Air compressors are designed for production reliability, with little understanding or regard for the cost impacts of underutilization and performance issues. As a result, compressed air systems are typically:**

- Inefficiently operated and maintained
- Prone to pressure and fluctuations
- Over-designed with excess capacity
- Plagued by infrastructure leaks
- Wasteful of electricity

COMPRESSED AIR SYSTEM	
OLD	NEW
Annual energy costs = \$169,000	Annual energy cost = \$77,000
Significant maintenance costs	Reliable energy-efficient equipment
Fluctuating pressure, 78 – 113 psig	Stabilized pressure, +/- 3 psi
Manual equipment control	Automated control system
Lack of historical data	Real-time & historical performance data
Poor air quality	Clean dry air

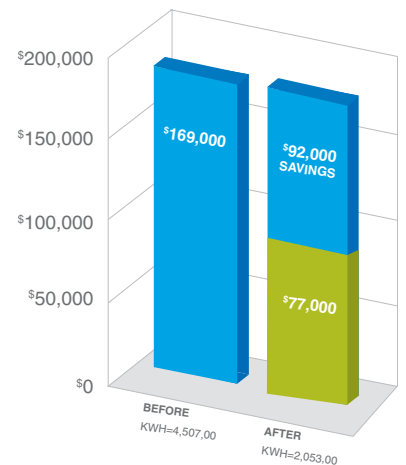

Success Story: Luzenac Talc Mill

“The average system is usually over-pressurized, and it fluctuates a lot. Pneu-Logic’s PL2000 actually makes decisions about what the system is requiring at any given time and provides just that much pressure. This ability to stabilize pressure is of tremendous value to industries.”

- John Campbell, Discovery Energy Solutions, A Montana Power Company

## PNEU-LOGIC SYSTEM INSTALLATION AND INTEGRATION

### Major components of the new compressed air system included:

- ▶ Pneu-Logic PL2000 networked, air flow-based compressed air management system
- ▶ Kaeser compressors, one variable frequency drive and two standard
- ▶ Conserv-AIR Intermediate controller
- ▶ Additional air storage vessels
- ▶ Pneumatech heated regenerative air dryer

### MODIFIED SYSTEM CONFIGURATION (Green representing system upgrades)

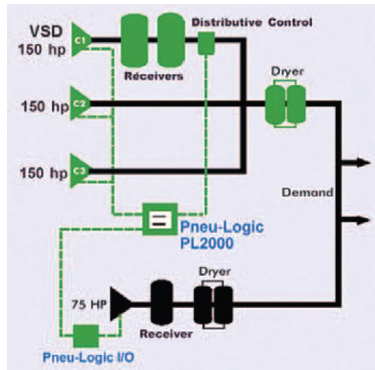

### BEFORE & AFTER Compressed Air System Pressure

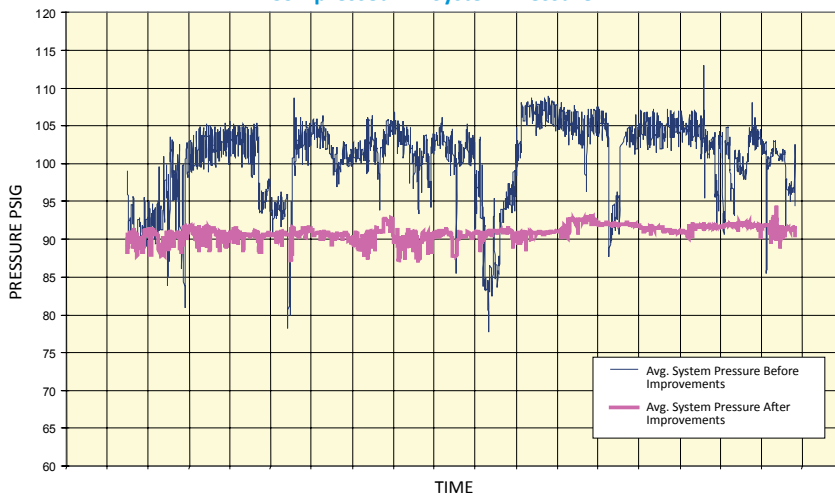

## About Pneu-Logic

Pneu-Logic is a privately owned company located in Portland, Oregon, with Authorized Resellers located in the US, EU, and South Africa. As the industry leader in advanced compressed air energy efficiency management systems and control technology, Pneu-Logic helps companies 1) substantially reduce industrial compressed air electrical energy consumption and costs through improved operational management and control efficiency, and 2) increase industrial net productivity by reducing process latency periods between demand and supply for air through “real time” compressed air flow management. Pneu-Logic also offers best-in-class compressed air engineering services and assessments.

## Contact Pneu-Logic

If you’re interested in learning more about our advanced systems and engineering services designed to decrease electrical energy costs and improve system performance, contact us today. Call us toll-free at 866.348.5669 or visit us on the web at [www.pneulogic.com](http://www.pneulogic.com).